



REVISED AND REPRINTED BY  
**CARTOGRAPHIC ASSOC. INC.**  
 PROFESSIONAL GIS CONSULTANTS  
 MUNICIPAL MAPPING - GIS - PUBLIC WORKS INFORMATION MANAGEMENT  
 11 PLEASANT STREET, LITTLETON, NEW HAMPSHIRE 03561  
 (603)444-6768 - 1(800)322-4540 - FAX (603)444-1366 - WWW.CAI-INFO.COM

THIS MAP IS FOR ASSESSMENT PURPOSES ONLY. IT IS NOT VALID FOR LEGAL DESCRIPTION OR CONVEYANCE. PARCELS AS SHOWN MAY REFLECT TOTAL CONTIGUOUS ACREAGE OWNED BY ONE OWNER FOR TAX BILLING PURPOSES.

THE HORIZONTAL DATUM IS THE MASSACHUSETTS STATE PLANE COORDINATE SYSTEM.

COMPLETION DATE: DECEMBER 29, 1989

REVISION DATE: JANUARY 1, 2008

LEGEND SYMBOLS	
PARCEL NUMBER	162
TOWN LINE	---
RIGHT OF WAY	----
EASEMENT	- - - -
PATH	----
SCHOOL	1
CHURCH	+
CEMETERY	+
STREAM	~ ~ ~ ~
CRANBERRY BOG	~ ~ ~ ~
POND	~ ~ ~ ~
WETLAND	~ ~ ~ ~

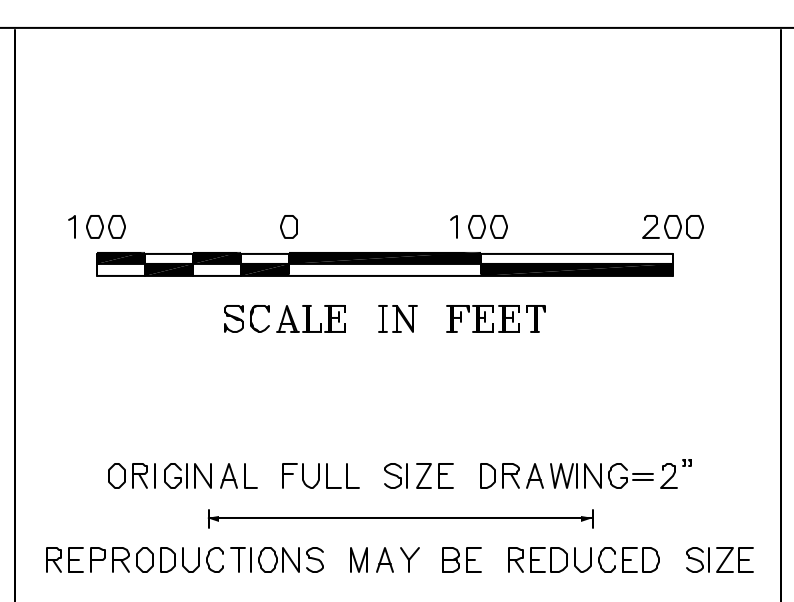

INDEX		
58	59	0
67	68	0
76	77	0

ASSESSORS MAP  
**TOWN OF KINGSTON**  
 MASSACHUSETTS

REVISED BY  
 Cartographic Assoc. 2008  
 Cartographic Assoc. 2005  
 Cartographic Assoc. 2004

MAP NO.  
**68**